

N-channel 525 V, 1.25 Ω typ., 4.4 A UltraFASTmesh™ Power MOSFET in a I²PAK package

Datasheet - not recommended for new design

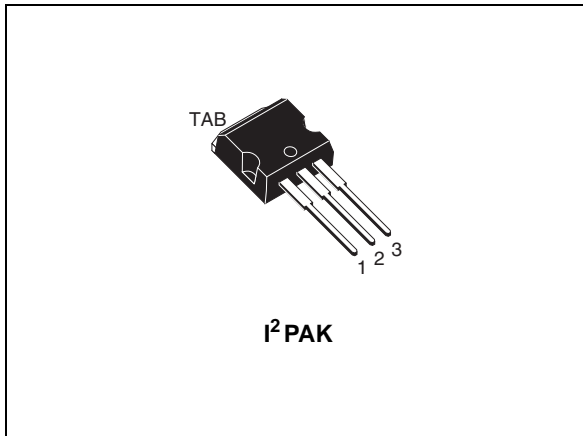
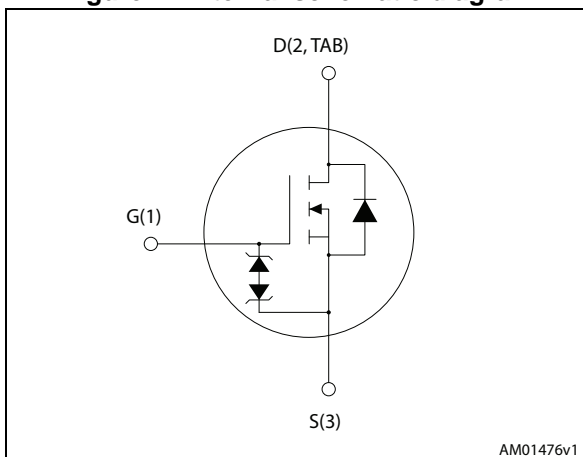

Figure 1. Internal schematic diagram



Features

Order codes	V _{DS}	R _{DS(on)} max	I _D	P _{TOT}
STI5N52U	525 V	1.5 Ω	4.4 A	70 W

- Outstanding dv/dt capability
- Gate charge minimized
- Very low intrinsic capacitances
- Very low R_{DS(on)}
- Extremely low t_{rr}

Applications

- Switching applications

Description

This device is an N-channel Power MOSFET developed using UltraFASTmesh™ technology, which combines the advantages of reduced on-resistance, Zener gate protection and very high dv/dt capability with an enhanced fast body-drain recovery diode.

Table 1. Device summary

Order code	Marking	Package	Packaging
STI5N52U	5N52U	I ² PAK	Tube

Contents

1	Electrical ratings	3
2	Electrical characteristics	4
2.1	Electrical characteristics (curves)	6
3	Test circuits	8
4	Package mechanical data	9
5	Revision history	11

1 Electrical ratings

Table 2. Absolute maximum ratings

Symbol	Parameter	Value	Unit
V_{GS}	Gate- source voltage	± 30	V
I_D	Drain current (continuous) at $T_C = 25\text{ }^\circ\text{C}$	4.4	A
I_D	Drain current (continuous) at $T_C = 100\text{ }^\circ\text{C}$	2.8	A
$I_{DM}^{(1)}$	Drain current (pulsed)	17.6	A
P_{TOT}	Total dissipation at $T_C = 25\text{ }^\circ\text{C}$	70	W
I_{AR}	Avalanche current, repetitive or not-repetitive (pulse width limited by T_J max)	4.4	A
E_{AS}	Single pulse avalanche energy (starting $T_J = 25\text{ }^\circ\text{C}$, $I_D = I_{AR}$, $V_{DD} = 50\text{ V}$)	170	mJ
$dv/dt^{(2)}$	Peak diode recovery voltage slope	20	V/ns
ESD	Gate-source human body model ($R = 1.5\text{ k}\Omega$, $C = 100\text{ pF}$)	2800	kV
T_J	Operating junction temperature	-55 to 150 $^\circ\text{C}$	$^\circ\text{C}$
T_{stg}	Storage temperature		$^\circ\text{C}$

1. Pulse width limited by safe operating area.

2. $I_{SD} \leq 4.4\text{ A}$, $di/dt \leq 400\text{ A}/\mu\text{s}$, peak $V_{DS} \leq V_{(BR)DSS}$

Table 3. Thermal data

Symbol	Parameter	Value	Unit
$R_{thj-case}$	Thermal resistance junction-case max	1.78	$^\circ\text{C}/\text{W}$
$R_{thj-amb}$	Thermal resistance junction-ambient max	100	$^\circ\text{C}/\text{W}$

2 Electrical characteristics

(T_{case} = 25 °C unless otherwise specified).

Table 4. On /off states

Symbol	Parameter	Test conditions	Min.	Typ.	Max.	Unit
V _{(BR)DSS}	Drain-source breakdown voltage (V _{GS} = 0)	I _D = 1 mA	525			V
I _{DSS}	Zero gate voltage drain current (V _{GS} = 0)	V _{DS} = 525 V			10	μA
		V _{DS} = 525 V, T _C = 125 °C			500	μA
I _{GSS}	Gate-body leakage current (V _{DS} = 0)	V _{GS} = 20 V			±10	μA
V _{GS(th)}	Gate threshold voltage	V _{DS} = V _{GS} , I _D = 50 μA	3	3.75	4.5	V
R _{DS(on)}	Static drain-source on-resistance	V _{GS} = 10 V, I _D = 2.2 A		1.25	1.5	Ω

Table 5. Dynamic

Symbol	Parameter	Test conditions	Min.	Typ.	Max.	Unit
C _{iss}	Input capacitance	V _{DS} = 25 V, f = 1 MHz, V _{GS} = 0	-	529	-	pF
C _{oss}	Output capacitance		-	71	-	pF
C _{rss}	Reverse transfer capacitance		-	13.4	-	pF
C _{o(tr)} ⁽¹⁾	Equivalent capacitance time related	V _{DS} = 0 to 420 V, V _{GS} = 0	-	11	-	pF
R _g	Gate input resistance	f = 1 MHz open drain	-	6	-	Ω
Q _g	Total gate charge	V _{DD} = 416 V, I _D = 4.4 A, V _{GS} = 10 V (see Figure 15)	-	16.9	-	nC
Q _{gs}	Gate-source charge		-	4.2	-	nC
Q _{gd}	Gate-drain charge		-	8.4	-	nC

1. C_{oss eq.} time related is defined as a constant equivalent capacitance giving the same charging time as C_{oss} when V_{DS} increases from 0 to 80% V_{DSS}

Table 6. Switching times

Symbol	Parameter	Test conditions	Min.	Typ.	Max.	Unit
$t_{d(on)}$	Turn-on delay time	$V_{DD} = 260\text{ V}$, $I_D = 2.2\text{ A}$, $R_G = 4.7\ \Omega$, $V_{GS} = 10\text{ V}$ (see Figure 14)	-	11.4	-	ns
t_r	Rise time		-	13.6	-	ns
$t_{d(off)}$	Turn-off-delay time		-	23.1	-	ns
t_f	Fall time		-	15	-	ns

Table 7. Source drain diode

Symbol	Parameter	Test conditions	Min.	Typ.	Max.	Unit
I_{SD}	Source-drain current		-		4.4	A
$I_{SDM}^{(1)}$	Source-drain current (pulsed)		-		17.6	A
$V_{SD}^{(2)}$	Forward on voltage	$I_{SD} = 4.4\text{ A}$, $V_{GS} = 0$	-		1.6	V
t_{rr}	Reverse recovery time	$I_{SD} = 4.4\text{ A}$, $di/dt = 100\text{ A}/\mu\text{s}$ $V_{DD} = 60\text{ V}$ (see Figure 16)	-	55		ns
Q_{rr}	Reverse recovery charge		-	95		nC
I_{RRM}	Reverse recovery current		-	3.5		A
t_{rr}	Reverse recovery time	$I_{SD} = 4.4\text{ A}$, $di/dt = 100\text{ A}/\mu\text{s}$ $V_{DD} = 60\text{ V}$, $T_J = 150\text{ }^\circ\text{C}$ (see Figure 16)	-	120		ns
Q_{rr}	Reverse recovery charge		-	266		nC
I_{RRM}	Reverse recovery current		-	4.5		A

1. Pulse width limited by safe operating area
2. Pulsed: pulse duration = 300 μs , duty cycle 1.5%

Table 8. Gate-source Zener diode

Symbol	Parameter	Test conditions	Min	Typ.	Max.	Unit
$V_{(BR)GSO}$	Gate-source breakdown voltage	$I_{GS} = \pm 1\text{ mA}$, $I_D = 0$	30	-	-	V

The built-in back-to-back Zener diodes have specifically been designed to enhance the device's ESD capability. In this respect the Zener voltage is appropriate to achieve an efficient and cost-effective intervention to protect the device's integrity. These integrated Zener diodes thus avoid the usage of external components.

2.1 Electrical characteristics (curves)

Figure 2. Safe operating area

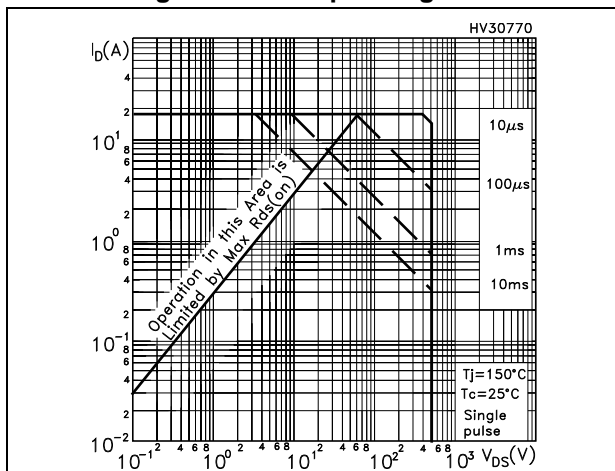

Figure 3. Thermal impedance

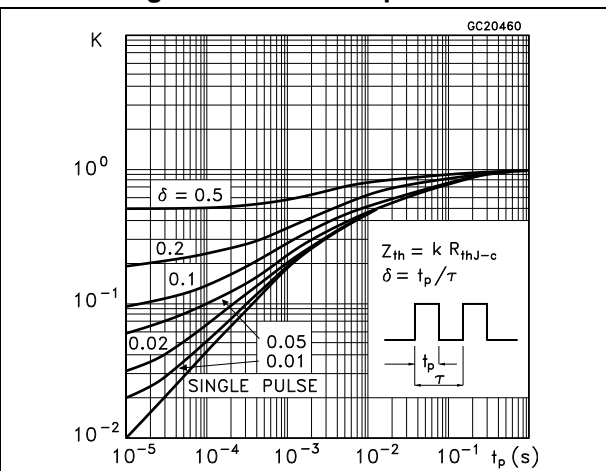

Figure 4. Output characteristics

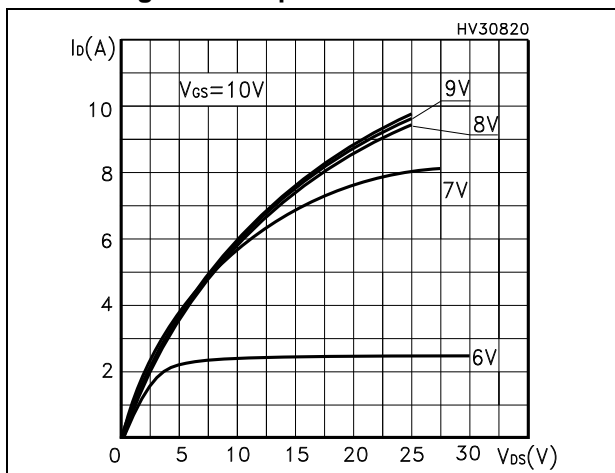

Figure 5. Transfer characteristics

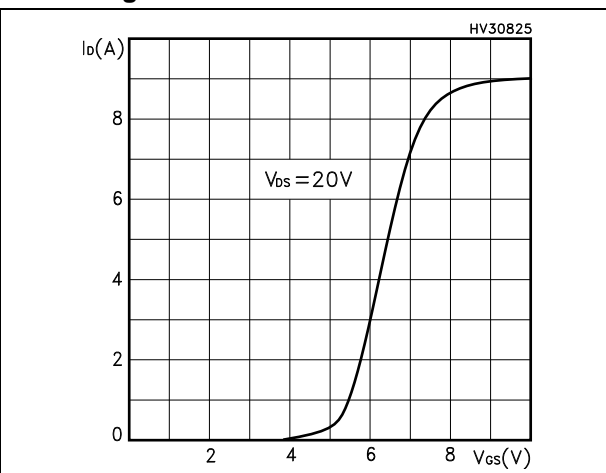

Figure 6. Normalized $V_{(BR)DSS}$ vs temperature

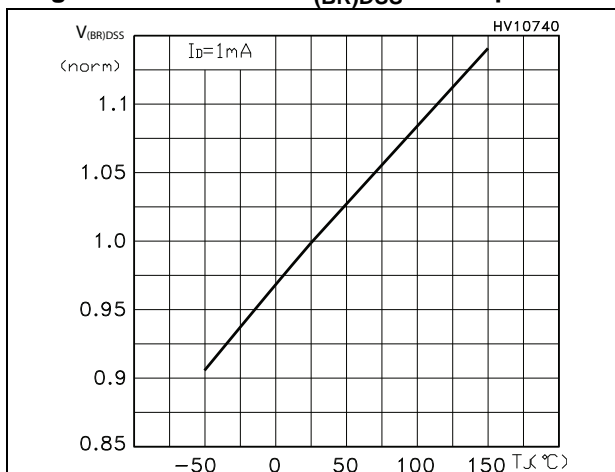

Figure 7. Static drain-source on resistance

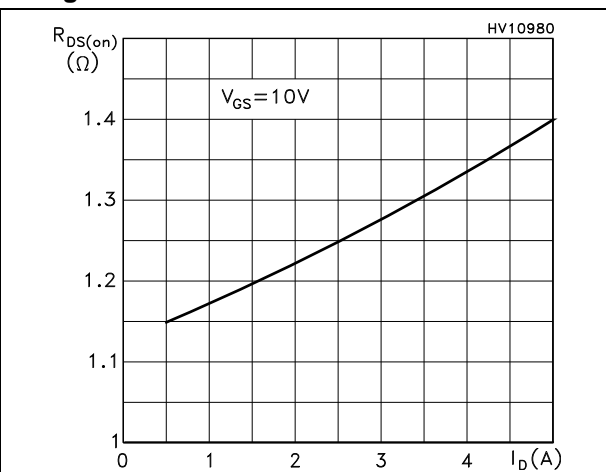

Figure 8. Gate charge vs gate-source voltage

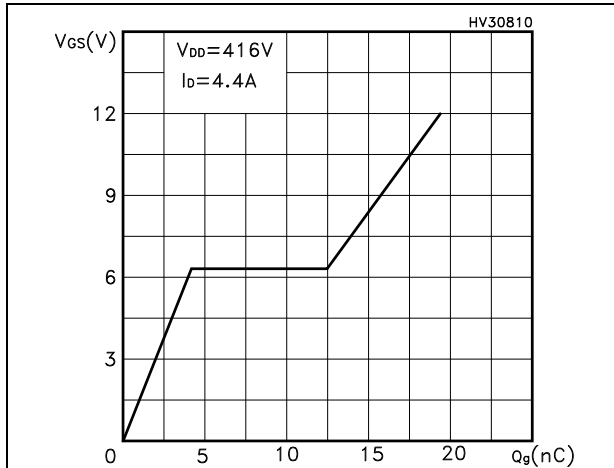

Figure 9. Capacitance variations

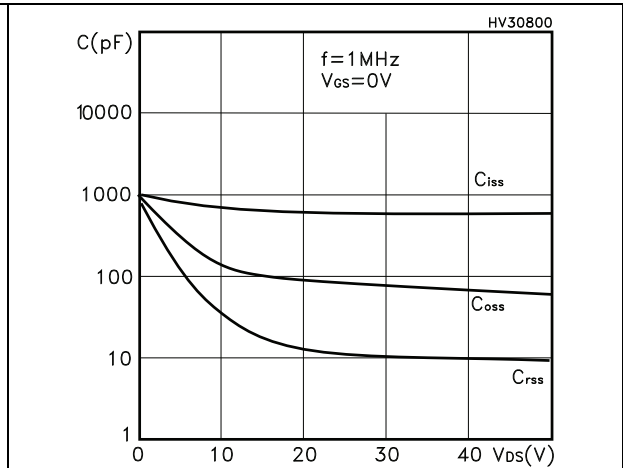

Figure 10. Normalized gate threshold voltage vs temperature

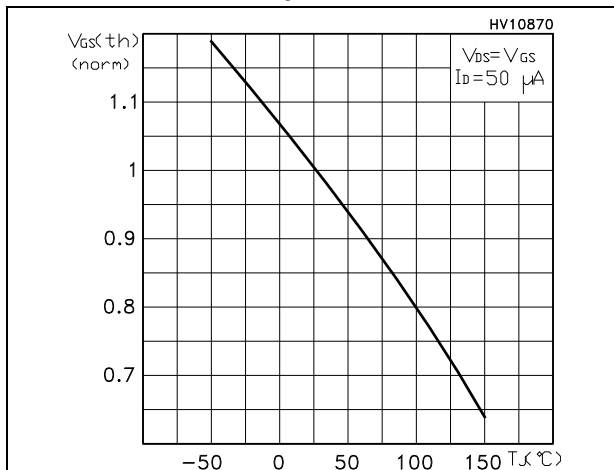

Figure 11. Normalized on-resistance vs temperature

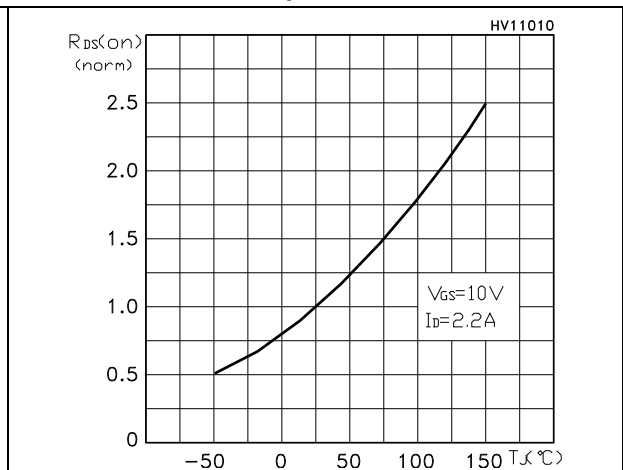

Figure 12. Source-drain diode forward characteristics

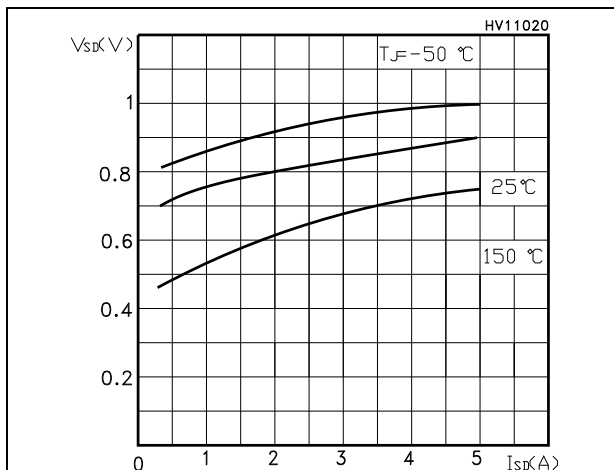
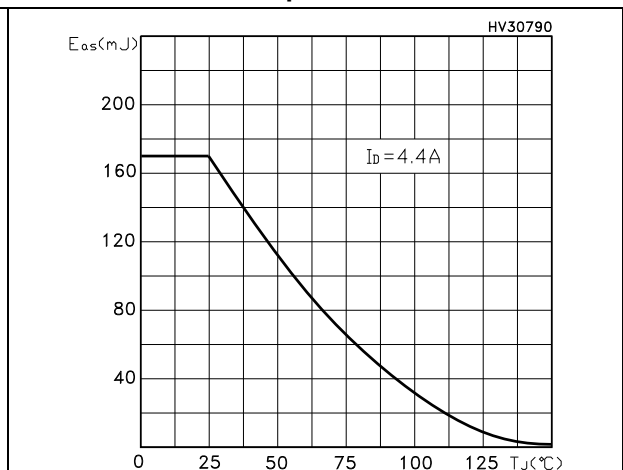
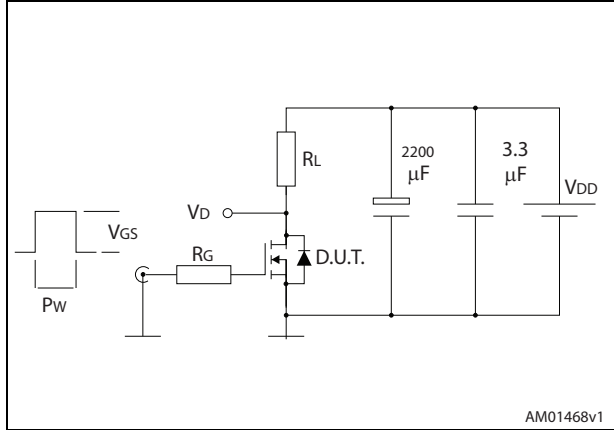

Figure 13. Maximum avalanche energy vs temperature



3 Test circuits

Figure 14. Switching times test circuit for resistive load



AM01468v1

Figure 15. Gate charge test circuit

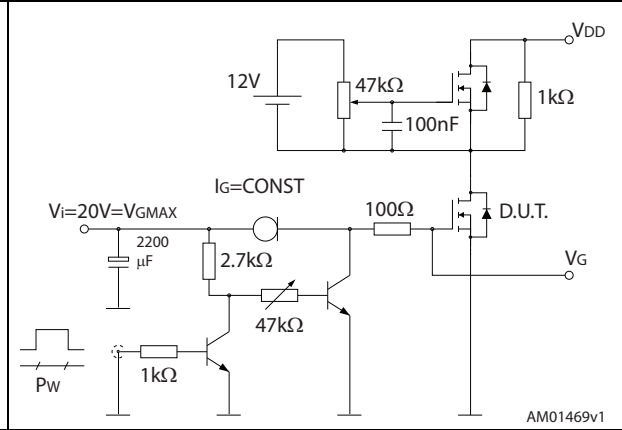

AM01469v1

Figure 16. Test circuit for inductive load switching and diode recovery times

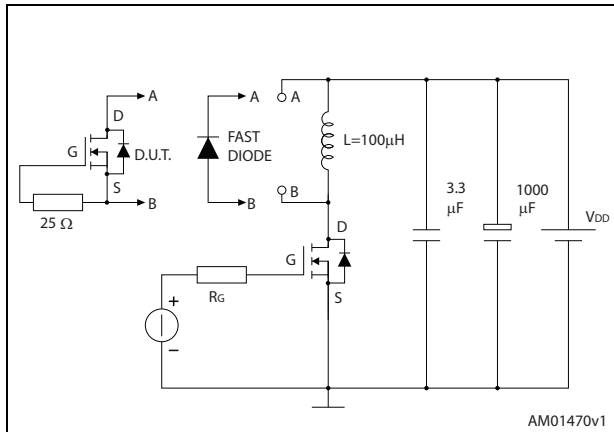

AM01470v1

Figure 17. Unclamped inductive load test circuit

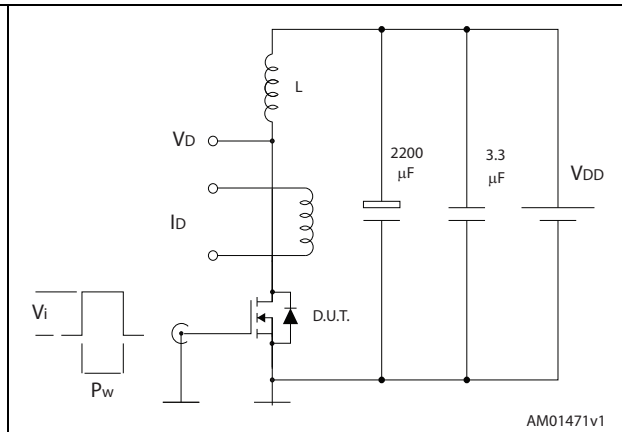

AM01471v1

Figure 18. Unclamped inductive waveform

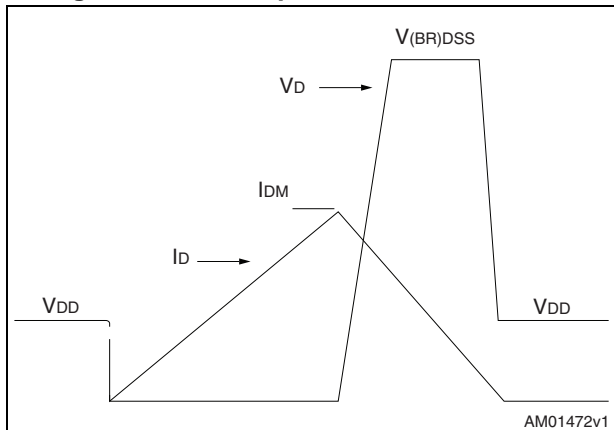

AM01472v1

Figure 19. Switching time waveform

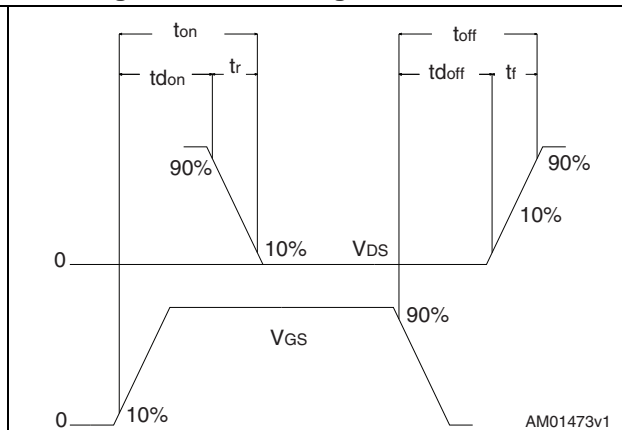

AM01473v1

4 Package mechanical data

In order to meet environmental requirements, ST offers these devices in different grades of ECOPACK[®] packages, depending on their level of environmental compliance. ECOPACK[®] specifications, grade definitions and product status are available at: www.st.com. ECOPACK[®] is an ST trademark.

Figure 20. I²PAK (TO-262) drawing

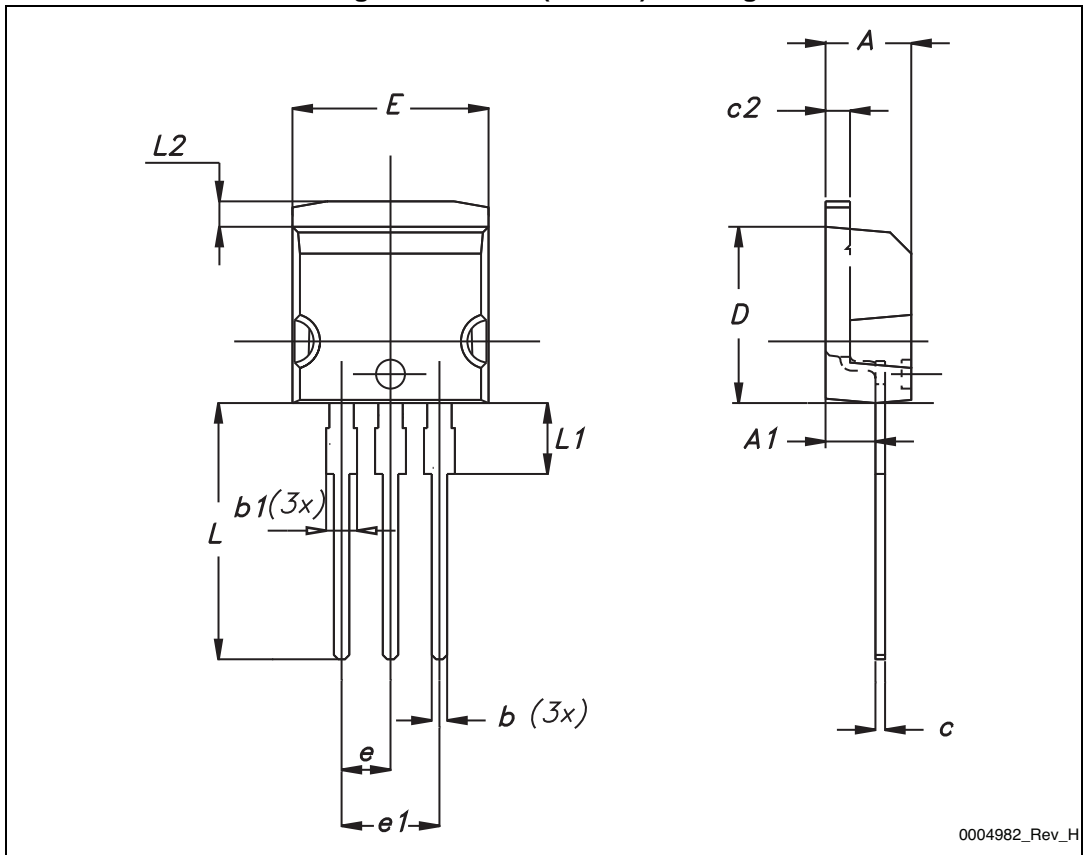

0004982_Rev_H

Table 9. I²PAK (TO-262) mechanical data

DIM.	mm.		
	min.	typ	max.
A	4.40		4.60
A1	2.40		2.72
b	0.61		0.88
b1	1.14		1.70
c	0.49		0.70
c2	1.23		1.32
D	8.95		9.35
e	2.40		2.70
e1	4.95		5.15
E	10		10.40
L	13		14
L1	3.50		3.93
L2	1.27		1.40

5 Revision history

Table 10. Document revision history

Date	Revision	Changes
23-Jul-2014	1	First release. Part number previously included in datasheet DocID15684

IMPORTANT NOTICE – PLEASE READ CAREFULLY

STMicroelectronics NV and its subsidiaries ("ST") reserve the right to make changes, corrections, enhancements, modifications, and improvements to ST products and/or to this document at any time without notice. Purchasers should obtain the latest relevant information on ST products before placing orders. ST products are sold pursuant to ST's terms and conditions of sale in place at the time of order acknowledgement.

Purchasers are solely responsible for the choice, selection, and use of ST products and ST assumes no liability for application assistance or the design of Purchasers' products.

No license, express or implied, to any intellectual property right is granted by ST herein.

Resale of ST products with provisions different from the information set forth herein shall void any warranty granted by ST for such product.

ST and the ST logo are trademarks of ST. All other product or service names are the property of their respective owners.

Information in this document supersedes and replaces information previously supplied in any prior versions of this document.

© 2014 STMicroelectronics – All rights reserved